

FlowSol® E

RESOL®

Manual for the
specialised craftsman

Installation
Operation
Commissioning



11210068

Thank you for buying this RESOL product.
Please read this manual carefully to get the best performance from this unit.
Please keep this manual safe.

en

Manual

www.resol.com

Safety advice

Please pay attention to the following safety advice in order to avoid danger and damage to people and property.

Instructions

Attention must be paid to the valid local standards, regulations and directives!

Information about the product

Proper usage

The electrothermal station is used for instantaneous water heating by means of an electric heater in compliance with the technical data limit values in this manual. Due to its design the station must be mounted and operated as described in these instructions!

CE-Declaration of conformity

The product complies with the relevant directives and is therefore labelled with the CE mark. The Declaration of Conformity is available upon request, please contact the manufacturer.



Target group

These instructions are exclusively addressed to authorised skilled personnel. Only qualified electricians should carry out electrical works. Initial installation must be effected by the system owner or qualified personnel named by the system owner.

Description of symbols

WARNING! Warnings are indicated with a warning triangle!
→ **They contain information on how to avoid the danger described.**



Signal words describe the danger that may occur, when it is not avoided.

- **WARNING** means that injury, possibly life-threatening injury, can occur.
- **ATTENTION** means that damage to the appliance can occur.



Note

Notes are indicated with an information symbol.

→ Arrows indicate instruction steps that should be carried out.

Disposal

- Dispose of the packaging in an environmentally sound manner.
- At the end of its working life, the product must not be disposed of as urban waste. Old appliances must be disposed of by an authorised body in an environmentally sound manner. Upon request we will take back your old appliances bought from us and guarantee an environmentally sound disposal of the devices.



FlowSol® E

The RESOL FlowSol® E has been especially designed for using excess power produced by a photovoltaic system.

The measuring device reliably detects excess current and the integrated controller redirects it to a steplessly variable electric heater for heating a water store.

Thus, excess power can be stored as regenerative heat, internal consumption can be increased while decreasing conventional heating costs.

Contents

1	Overview	4
1.1	System overview.....	5
2	Mounting	6
2.1	Wall mounting.....	6
2.2	Electrical connection	6
2.3	Hydraulic connection buffer store (heating water).....	7
3	Commissioning	8
3.1	Ball valve positions	8
3.2	Venting the FlowSol® E.....	8
4	Non-return valve	9
5	Maintenance	9
6	Troubleshooting	9
7	List of spare parts	10

1 Overview

- Integrated high-efficiency pump and *DeltaTherm*[®] E controller
- Integrated electric heater of up to 3 kW, steplessly variable and grid compliant
- Retrofittable in all heating and DHW systems
- Reliable household power priority

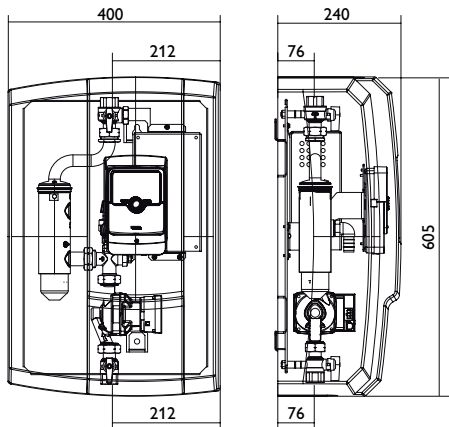

Technical data

Circulating pump:

Wilo Yonos PARA 15/7.0-PWM2 (heating water)
(power consumption of the pump: 3 ... 45 W)

Power supply: 220 ... 240 V~ (50 ... 60 Hz)

Cable cross section required: 2,5 mm²

Heating element: 0.8 kW / 0.8 kW / 1.4 kW

Nominal power / current: 0 ... 3 kW (13 A)

Safety valve: 3 bar (heating water)

Connections: RP 3/4" IT

Admissible max. temperature: 95 °C

Maximum pressure: 3 bar (heating water)

Medium: Heating water

Dimensions: approx. 605 x 400 x 240 mm (incl. insulation)

Distance centre/wall: 76 mm

Weight: 14 kg

Material:

Fittings: brass

Seals: EPDM

Insulation: EPP foam

Pressure loss/pump characteristics

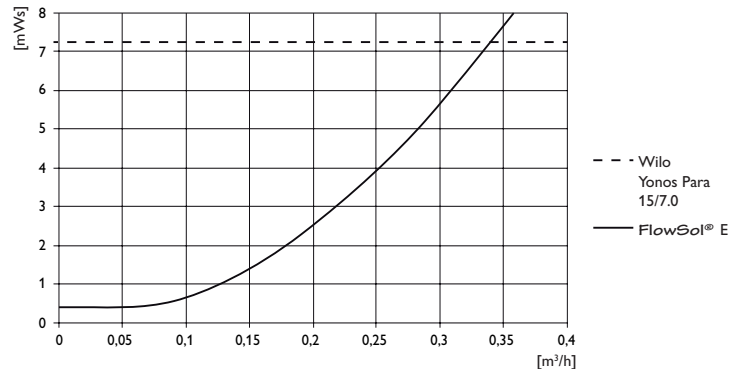

1.1 System overview

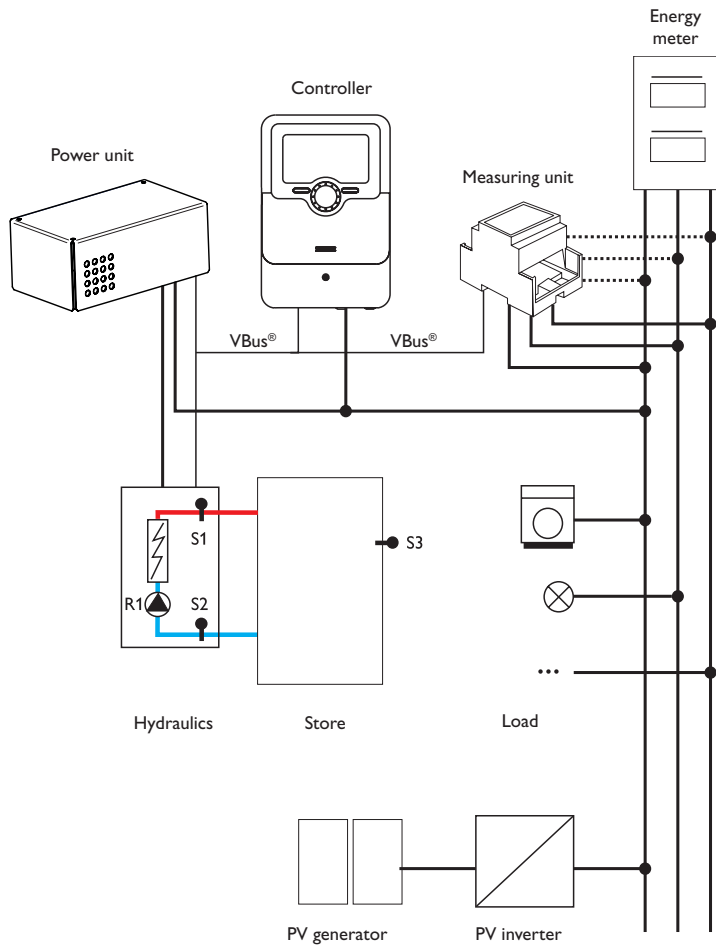

2 Mounting

2.1 Wall mounting

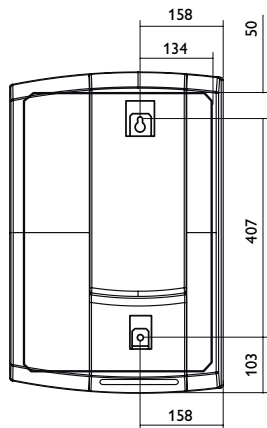

- Determine the mounting site of the station.
- Drill 2 holes (10 mm diameter, 407 mm centres) one below the other and insert wall plugs.
- Tighten the upper screw and washer, leaving the heat protruding (1 cm).
- Hang the station from the fastening point, adjust with a level and attach with the 2nd screw and washer.
- Tighten both screws equally.
- Connect the pipework between the station and the store.



Note

All connections are already tightened such that they usually do not have to be tightened again. However, during commissioning of the system all connections have to be checked for leaks (pressure test).

2.2 Electrical connection

WARNING! Electric shock!



Upon opening the housing, live parts are exposed!

→ **Always disconnect the device from power supply before opening the housing!**

ATTENTION! ESD damage!



Electrostatic discharge can lead to damage to electronic components!

→ **Take care to discharge properly before touching the inside of the device! To do so, touch a grounded surface such as a radiator or tap!**



Note

Connecting the device to the power supply must always be the last step of the installation!



Note

It must be possible to disconnect the device from the mains at any time.

- Install the mains plug such that it is accessible at any time.
- If this is not possible, install a switch that can be accessed.

Do not use the device if it is visibly damaged!

This station is already pre-assembled and pre-connected.

- Connect the mains cables and establish the bus connection to the controller.



Note

For more information about the electrical connection, see controller manual.

The station is supplied with power via a mains cable. The mains connection must be carried out by means of the plug (delivered with the station) and a separate 2.5 mm² line. The power supply must be 220 ... 240 V~ (50 ... 60 Hz).

Neutral conductor N

Conductor L

Protective conductor ⊕

→ Put the cover on the plug.

The cover also serves as a strain relief.

→ Connect the plug to the connector attached to the base plate.

Further loads such as washing machines must not be connected in parallel to the station.

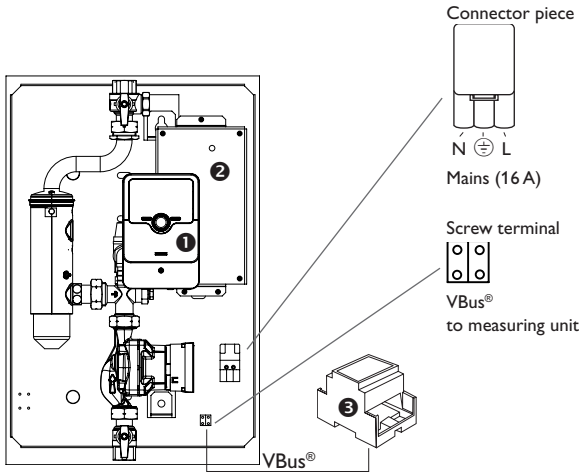

❶ DeltaTherm® E controller

❷ DeltaTherm® E Power power unit

❸ DeltaTherm® E Sensor measuring unit and current sensors

The bus cable can be extended with a two-wire cable (bell wire). The cable carries low voltage and must not run together in a cable conduit with cables carrying a higher voltage than 50 V (please pay attention to the valid local regulations). The cross section must be at least 0.5 mm² and the cable can be extended up to 50 m in the case of a single connection.

2.3 Hydraulic connection buffer store (heating water)

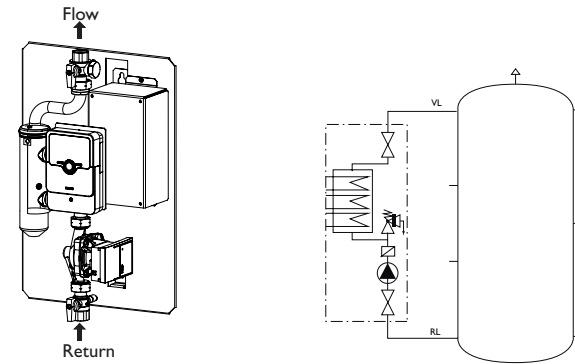

Designation	Description
FL	Flow
RE	Return

3 Commissioning

When the hydraulic system is filled and ready for operation, connect the power unit to the mains. The controller has to be connected to the power unit (pre-connected) and to the measuring unit by means of the VBus®.

ATTENTION! Damage by overheating!



Commissioning the station in a system ready for operation which is not hydraulically filled can lead to damage caused by overheating!

→ Before commissioning, fill the system with water and vent it.

- Check the station for leaks and seal, if necessary.
- Fill the heating water system (HW) with filtered (and treated) water only and vent the system completely.

3.1 Ball valve positions

WARNING! Scald danger! Damage by overpressure!



When the ball valve is closed, too high pressure may occur in the blocked-off line if it is heated.

→ In order to prevent scald danger and damage by overpressure, make sure the blocked-off line is not heated.

Ball valve in operating position

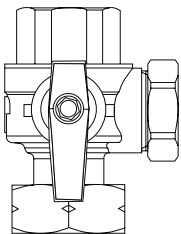

Ball valve in service position

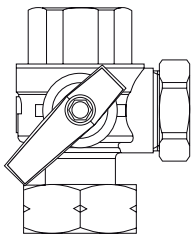

Ball valve closed

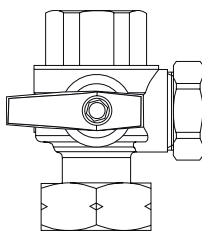

3.2 Venting the FlowSol® E

- Fill the system with water.
- Put the ball valve in the flow line to the service position (see figure).
- Switch-on the circulating pump at 10% speed for 1 min.
- Put the ball valve in the flow into the operating position.

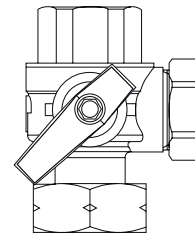

4 Non-return valve

The non-return valve is located above the pump in the return line.

5 Maintenance

In order to remove limescale, we recommend cleaning the heating element and the throttle orifice annually.

ATTENTION! Damage caused by improper cleaning fluids!



Using cleaning fluids not suited for high-grade steel, copper or nickel can damage the heating element!

→ Use cleaning fluids according to the manufacturer's instructions only.

For the cleaning fluid, use chloride-free or low-chloride water with low hardness.

Cleaning the heating element

In order to clean the heating element, carry out the following steps:

- Remove the heating element.
- Flush the heating element with appropriate cleaning fluid against the normal flow direction.
- Flush the cleaned heating element and the system with clear water.

Cleaning the throttle orifice

- In order to clean the throttle orifice, close both ball valves.

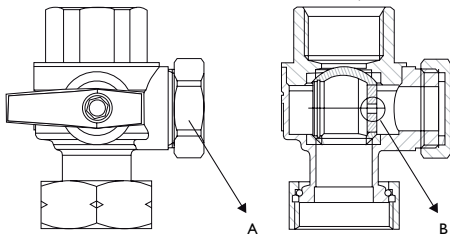

- Remove the lateral cover (A) at the ball valve in the flow and clean the throttle orifice (B).

6 Troubleshooting

If an error has occurred, it will be indicated on the controller screen. Please pay attention to the controller manual!

Fault condition	Possible cause	Elimination
Pump noise	Air inside the system	Vent the system
	Water pressure too low	Check and increase pressure if necessary
	Heat exchanger calcified	Decalcification / replacement
Flow rate too low (ΔT too high)	Throttle orifice polluted	Clean throttle orifice, see maintenance
	Non-return valve blocked (error message = red LED at pump head)	Control pump at 10% speed in manual operation
Target temperature not reached	Incorrect controller adjustment	Check adjustments
	Controller not in operation	Check controller
Heating element does not heat	Temperature sensor not correctly connected or defective	Check or replace, if necessary
	Pump defective	Check or replace, if necessary
	Thermal cut-out triggered	Reset (below black cover in DeltaTherm® E Power)

7 List of spare parts

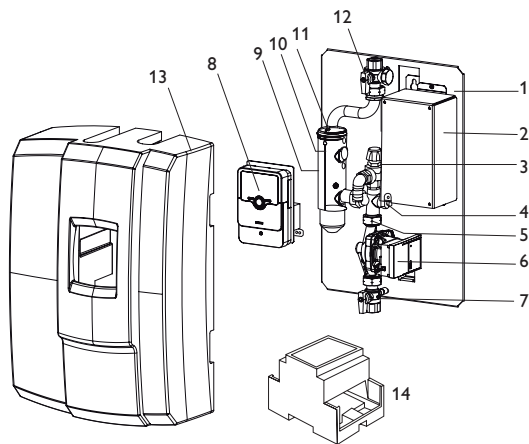

Pos.	Designation	Spare part number
1	Wall plate	-
2	DeltaTherm® E Power (incl. thermal cut-out)	11209970
3	Cross piece with safety valve HW	11209948
4	Temperature sensor Store (S2)	11211397
5	Non-return valve	see cross piece
6	Circulating pump HW	11209952
7	Return ball valve (RE)	11209953
8	DeltaTherm® E	11209950
9	Heating element	11209956
10	Thermal cut-out	11211398
11	Temperature sensor (S1)	11211399
12	Flow ball valve (FL)	11209959
13	Insulation	11209961
14	Sensor module DeltaTherm® E sensor incl. current sensors	11209960
	Spare fuses FlowSol® E	29003090

Distributed by:

RESOL – Elektronische Regelungen GmbH

Heiskampstraße 10

45527 Hattingen / Germany

Tel.: +49 (0) 23 24/96 48 - 0

Fax: +49 (0) 23 24/96 48 - 755

www.resol.com

info@resol.com

Important note

The texts and drawings in this manual are correct to the best of our knowledge. As faults can never be excluded, please note:

Your own calculations and plans, under consideration of the current standards and directions should only be basis for your projects. We do not offer a guarantee for the completeness of the drawings and texts of this manual - they only represent some examples. They can only be used at your own risk. No liability is assumed for incorrect, incomplete or false information and / or the resulting damages.

Note

The design and the specifications can be changed without notice.

The illustrations may differ from the original product.

Imprint

This mounting- and operation manual including all parts is copyrighted. Another use outside the copyright requires the approval of RESOL – Elektronische Regelungen GmbH. This especially applies for copies, translations, micro films and the storage into electronic systems.

© **RESOL – Elektronische Regelungen GmbH**