

WMZ Plus

Beginning with firmware version 1.01

RESOL®

Calorimeter

Manual for the
specialised craftsman

Installation

Operation

Functions and options

Troubleshooting

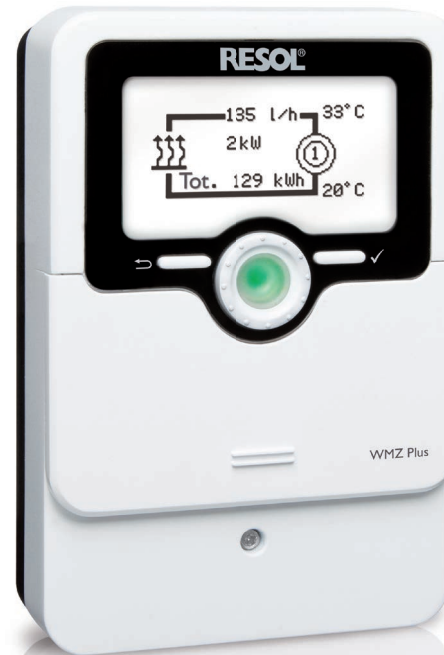

11211576



The Internet portal for easy and secure access to your system
data – www.vbus.net

Thank you for buying this RESOL product.

Please read this manual carefully to get the best performance from this unit. Please keep this manual safe.

en

Manual

www.resol.com

Safety advice

Please pay attention to the following safety advice in order to avoid danger and damage to people and property.

Danger of electric shock:

- When carrying out works, the device must first of all be disconnected from the mains.
- It must be possible to disconnect the device from the mains at any time.
- Do not use the device if it is visibly damaged!

Instructions

Attention must be paid to the valid local standards, regulations and directives!

Information about the product

Proper usage

The WMZ Plus is designed for measuring and indicating heat quantities in compliance with the technical data specified in this manual.

The WMZ Plus is not suitable for billing purposes.

Improper use excludes all liability claims.

EU Declaration of conformity

The product complies with the relevant directives and is therefore labelled with the CE mark. The Declaration of Conformity is available upon request, please contact the manufacturer.



Note

Strong electromagnetic fields can impair the function of the device.

- ➔ Make sure the device as well as the system are not exposed to strong electromagnetic fields.

Subject to technical change. Errors excepted.

Target group

These instructions are exclusively addressed to authorised skilled personnel. Only qualified electricians are allowed to carry out electrical works. Initial commissioning must be effected by authorised skilled personnel.

Description of symbols

WARNING!

Warnings are indicated with a warning triangle!



➔ They contain information on how to avoid the danger described.

Signal words describe the danger that may occur, when it is not avoided.

- **WARNING** means that injury, possibly life-threatening injury, can occur.
- **ATTENTION** means that damage to the appliance can occur.



Note

Notes are indicated with an information symbol.

- ➔ Arrows indicate instruction steps that should be carried out.

Disposal

- Dispose of the packaging in an environmentally sound manner.
- At the end of its working life, the product must not be disposed of as urban waste. Old appliances must be disposed of by an authorised body in an environmentally sound manner. Upon request we will take back your old appliances bought from us and guarantee an environmentally sound disposal of the devices.



WMZ Plus Calorimeter

Universal calorimeter module for solar, heating and cooling systems. Graphic display for indication of flow and return temperature, heat quantity, flow rate and sensor faults (balance values are also stored in case of a power failure). Suited for systems with water or water-glycol mixtures (water, propylene glycol, ethylene glycol and Tyfocor® LS adjustable).

The WMZ Plus meters the heat quantity as well as the cold quantity. The total energy results from the sum of heat and cold energy.

Contents

1	Overview	4	10	Single and cascade operation	17
2	Installation	5	10.1	Single operation.....	17
2.1	Mounting.....	5	10.2	Cascade without controller.....	17
2.2	Electrical connection.....	6	10.3	Cascade with controller.....	17
2.3	Data communication /bus	7	11	Basic settings	18
2.4	MicroSD card slot.....	8	12	MicroSD card	18
3	Operation and function	8	13	User code	19
3.1	Buttons and adjustment dial.....	8	14	Troubleshooting	20
3.2	Control lamp.....	8	15	Accessories	21
3.3	Parameterisation mode	9	16	Index	23
3.4	Selecting menu points and adjusting values	9			
3.5	Menu structure.....	10			
4	Flow rate sensors	11			
5	Commissioning	12			
6	Main menu	14			
7	Status	14			
7.1	Status	14			
7.2	HQM.....	15			
7.3	Service.....	15			
8	Balance values	15			
9	HQM	16			

1 Overview

- Single or combined measurement of heat and cold energy
- Two independent calorimeters
- Commissioning menu for easy configuration
- Conversion into selectable alternative units (€, kg CO₂, m³ gas, etc.)

Application example

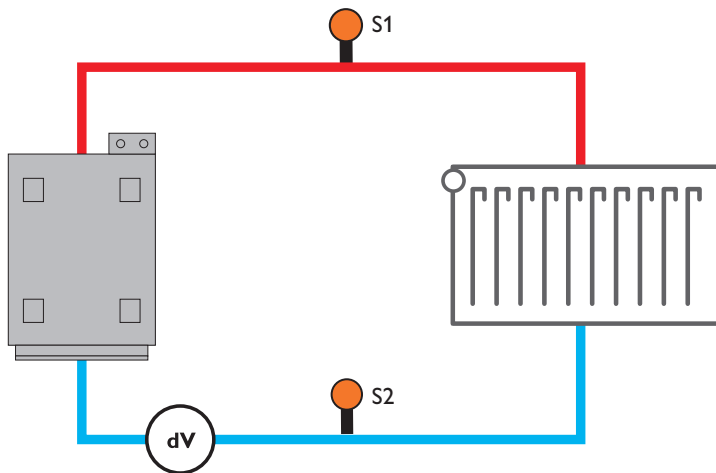

Technical data

Inputs: 4 Pt1000 temperature sensors, 2 impulse inputs (adjustable), 2 4-20 mA inputs (convertible to 0-10 V), 2 analogue Grundfos Direct Sensors™ (VFS)

Outputs: 2 S0 outputs

Power supply: 100–240 V~ (50–60 Hz)

Standby: < 1 W

Settings:

- **Volumetric content of glycol:** 0 ... 70 % (1-% steps)
- **Impulse rate of flow rate:** 0 ... 99 l/Imp (1-l/Imp steps) for V40 flowmeter

Temperature measurement: with Pt1000 sensors and Grundfos Direct Sensors™ (VFS)

Measuring precision: ± 0.3 K

Measuring range: -40 ... +120 °C (depending on the medium)

Data interface: VBus®, MicroSD card slot

VBus® current supply: 60 mA

Housing: plastic, PC-ABS and PMMA

Mounting: wall mounting, also suitable for mounting into patch panels

Indication/Display: graphic display, operating control LED (Lightwheel®)

Operation: 2 push buttons and 1 adjustment dial (Lightwheel®)

Ingress protection: IP 20/EN 60529

Ambient temperature: 0 ... 40 °C

Dimensions: 110 x 166 x 47 mm

2 Installation

2.1 Mounting

WARNING! Electric shock!



Upon opening the housing, live parts are exposed!

→ **Always disconnect the device from power supply before opening the housing!**



Note

Strong electromagnetic fields can impair the function of the device.

→ Make sure the device as well as the system are not exposed to strong electromagnetic fields.

The unit must only be located in dry interior rooms.

If the device is not equipped with a mains connection cable and a plug, the device must additionally be supplied from a double pole switch with contact gap of at least 3 mm.

Please pay attention to separate routing of sensor cables and mains cables.

In order to mount the device to the wall, carry out the following steps:

- Unscrew the crosshead screw from the cover and remove it along with the cover from the housing.
- Mark the upper fastening point on the wall. Drill and fasten the enclosed wall plug and screw leaving the head protruding.
- Hang the housing from the upper fastening point and mark the lower fastening point (centres 130 mm).
- Insert lower wall plug.
- Fasten the housing to the wall with the lower fastening screws and tighten.
- Carry out the electrical wiring in accordance with the terminal allocation (see page 14).
- Put the cover on the housing.
- Attach with the fastening screw.

Dimensions and minimum distances

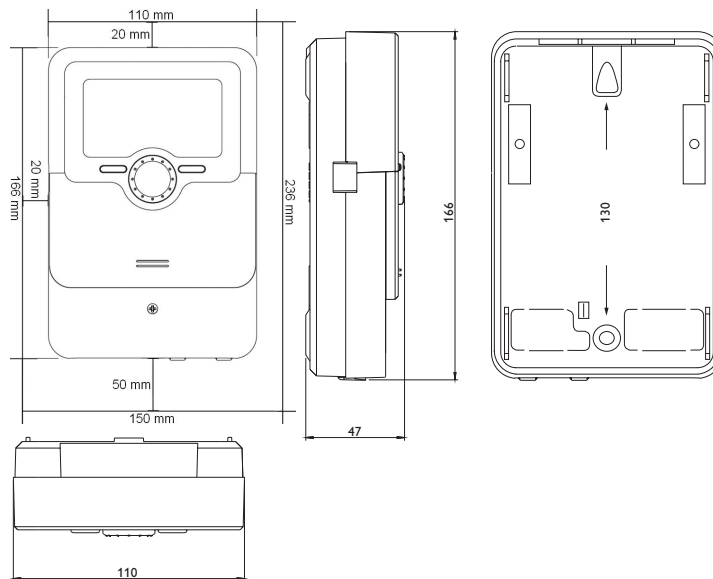

2.2 Electrical connection

WARNING!

Electric shock!

Upon opening the housing, live parts are exposed!

→ **Always disconnect the device from power supply before opening the housing!**



ATTENTION!

ESD damage!

Electrostatic discharge can lead to damage to electronic components!

→ **Take care to discharge properly before touching the inside of the device! To do so, touch a grounded surface such as a radiator or tap!**



Note

Connecting the device to the power supply must always be the last step of the installation!



Note

It must be possible to disconnect the device from the mains at any time.

→ Install the mains plug so that it is accessible at any time.

→ If this is not possible, install a switch that can be accessed.

If the mains cable is damaged, it must be replaced by a special connection cable which is available from the manufacturer or its customer service.

Do not use the device if it is visibly damaged!

Depending on the product version, mains cables and sensor cables are already connected to the device. If that is not the case, please proceed as follows:

Attach flexible cables to the housing with the enclosed strain relief and the corresponding screws.

The stripped length of the cables must be at least 8 mm.

Connect the **temperature sensors** (S1 to S4) to the terminals S1 to S4 (either polarity).

S1 = Sensor 1 (flow HQM 1)

S2 = Sensor 2 (return HQM 1)

S3 = Sensor 3 (flow HQM 2)

S4 = Sensor 4 (return HQM 2)

The cables carry low voltage and must not run together in a cable conduit with cables carrying a voltage higher than 50 V (please pay attention to the valid local regulations). The cable lengths depend on the cross sectional area. Example: up to 100 m at 1.5 mm², up to 50 m at 0.75 mm². The cables can be extended with a two-wire cable.

K1 and **K2** are combined inputs for **flow rate sensors**.

The following table shows the terminal allocations for the different sensor types at the combined inputs (K1 – WMZ 1 / K2 – WMZ 2):

Terminal Sensor	GND Sensor ground	1 Flow rate signal (frequency)	2 Temperature	3 Flow rate	4 4-20 mA/0-10V	5 Power supply 5V
V40		✓				✓
VFS	✓		✓	✓		✓
SIKA	✓	✓				✓
FlowRotor	✓	✓				✓
U/I	✓				✓	
US Echo II	✓	✓				✓

Connection examples

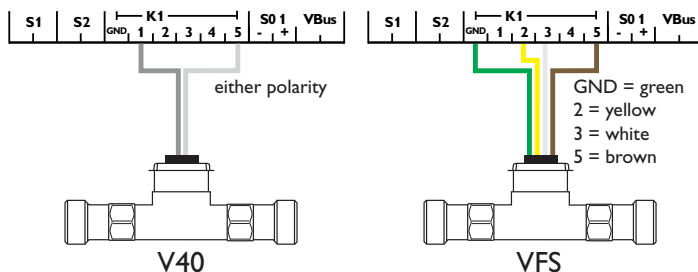

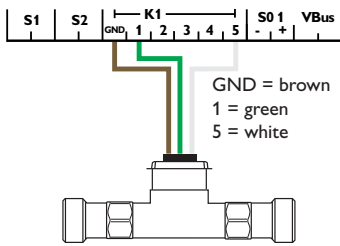

SIKA

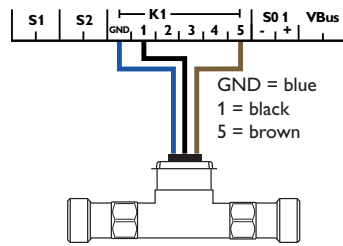

FlowRotor

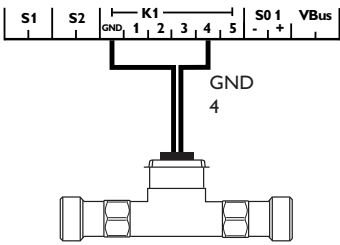

U/I

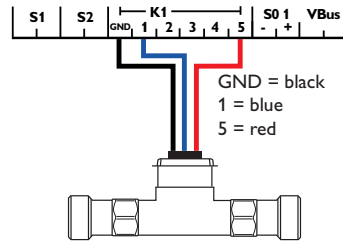

US Echo II

Note
If Grundfos Direct Sensors™ are used, connect GND of the combined inputs (K1/K2) to PE.

Note
Install the flow rate sensor into the return.

Connect the **V40** flowmeter to the terminals 1 and 5 of the corresponding combined input (either polarity).

The **S0 outputs** are used for issuing the energy quantity:

S0-1: HQM 1

S0-2: HQM 2

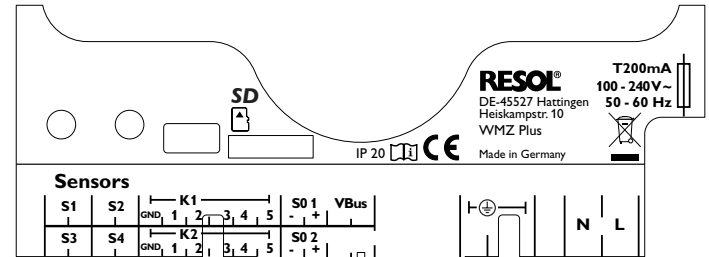

The device is supplied with power via a mains cable. The power supply of the device must be 100 ... 240 V~ (50 ... 60 Hz).

The **mains connection** is at the terminals:

- Neutral conductor N
- Conductor L
- Protective earth conductor ⊕

Note
For more details about the commissioning procedure see page 12.

2.3 Data communication / bus

The device is equipped with a **VBus**® for data transfer and energy supply to external modules. The connection is to be carried out at the terminals marked **VBus** (any polarity).

One or more **VBus**® modules can be connected via this data bus, such as:

- DL2/DL3 Datalogger
- KM2 Communication module

Note
If several **VBus**® accessories are used with a cascade, a **VBus**®-Repeater may be required. For more information about cascade operation, see page 17.

Note
For more information about accessories, see page 21.

2.4 MicroSD card slot

The device is equipped with a MicroSD card slot.

With a MicroSD card, the following functions can be carried out:

- Store measurement and balance values onto the MicroSD card. After the transfer to a computer, the values can be opened and visualised, e.g. in a spreadsheet.
- Store adjustments and parameterisations on the MicroSD card and, if necessary, retrieve them from there.
- Download firmware updates from the Internet and install them on the device via MicroSD card.

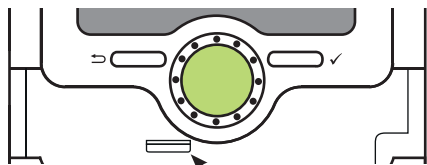

MicroSD card slot

A MicroSD card is not included, but can be purchased from the manufacturer.



Note

For more information about using a MicroSD card, see page 18.

3 Operation and function

3.1 Buttons and adjustment dial

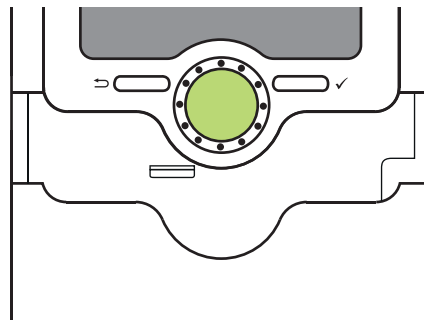

The device is operated via 2 buttons and 1 adjustment dial (Lightwheel®) below the display:



Left button (←) - escape button for changing into the previous menu

Right button (✓) - confirming/selecting

Lightwheel® - scrolling upwards/scrolling downwards, increasing adjustment values/reducing adjustment values

3.2 Control lamp

The device is equipped with a multicolour LED in the centre of the Lightwheel®, indicating the following states:

Colour	Permanently shown	Flashing
	Everything OK	
		Sensor line break, sensor short circuit
		Parameterisation active, update in progress, MicroSD card writing error

3.3 Parameterisation mode

After the installer code is entered (see page 19), the device changes to the parameterisation mode.



Note

In parameterisation mode, the metering process will stop and the message **Metering stopped – Parameterisation active** will be indicated. The LED in the Lightwheel® will glow yellow.

- ➔ In order to carry out adjustments in the menu, press the right button (✓).
- The device changes to the main menu in which adjustments on the installer level can be made.
- ➔ In order to save the adjustments made, select the menu item **Save** in the main menu.
- The device will leave the installer level and restart.

3.4 Selecting menu points and adjusting values

During normal operation of the device, the display indicates the main menu.

If no button is pressed for 2 min, the display illumination switches off. After another 2 min, the device changes to the status display.

In order to get from the status menu into the main menu, press the left button (←)! Press any key to reactivate the display illumination. In order to scroll through the menu items, turn the Lightwheel®.

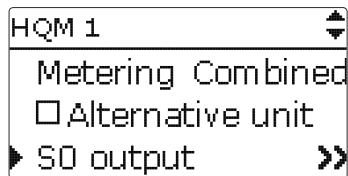

If the symbol **»** is shown behind a menu item, pressing the right button (✓) will open a new submenu.

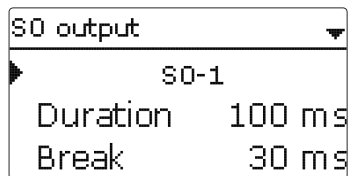

Values and options can be changed in different ways:

Numeric values can be adjusted by means of a slide bar. The minimum value is indicated to the left, the maximum value to the right. The large number above the slide bar indicates the current adjustment. By turning the Lightwheel®, the upper slide bar can be moved to the left or to the right.

Only after the adjustment has been confirmed by pressing the right button (✓) will the number below the slide bar indicate the new value. The new value will be saved if it is confirmed by pressing the right button (✓) again.

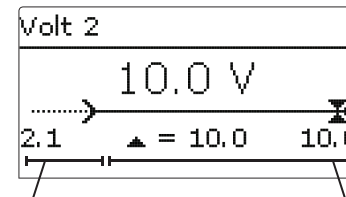

inactive area

active area

When 2 values are locked against each other, they will display a reduced adjustment range depending on the adjustment of the respective other value.

In this case, the active area of the slide bar is shortened, the inactive area is indicated as a dotted line. The indication of the minimum and maximum values will adapt to the reduction.

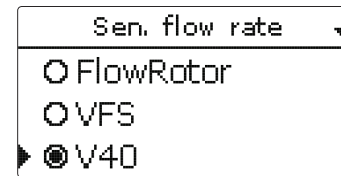

If only one item of several can be selected, they will be indicated with radio buttons. When one item has been selected, the radio button in front of it is filled.

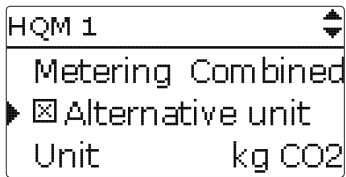

If more than one item of several can be selected, they will be indicated with checkboxes. When an item has been selected, an x appears inside the checkbox.

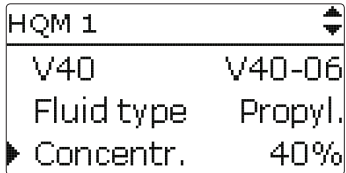

If further menu items are available and the symbol  is indicated on the upper right-hand side of the display, more menu items can be accessed by turning the Lightwheel®.

3.5 Menu structure

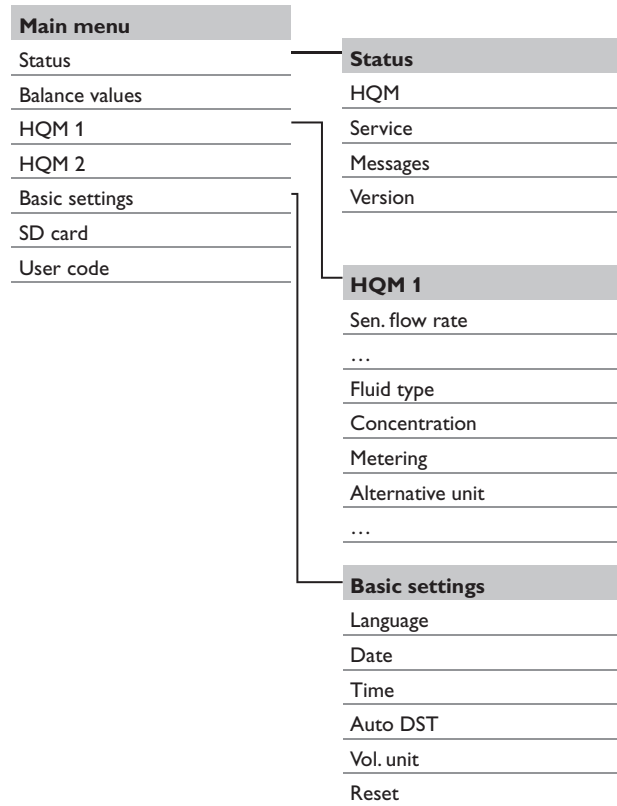

The menu items and adjustment values selectable are variable depending on adjustments already made. The figure only shows an exemplary excerpt of the complete menu in order to visualise the menu structure.

4 Flow rate sensors

The following flow rate sensor options are available:

- US Echo II
- SIKA
- U/I (sensors issuing voltage or current signals)
- FlowRotor
- VFS
- V40

Depending on the flow rate sensor selected further adjustment channels appear. The following table gives an overview of the sensors and the corresponding adjustment values.

Flow rate sensor	Corresponding adjustment channels	Description	Adjustment range/selection	Factory setting
US Echo II	US Echo II	Impulse rate	0.1 ... 100.0 l/Imp	1.0 l/Imp
SIKA	SIKA	Type	VY1030M, VY1030K, VTY20	VTY20
	U/I	Voltage or current signal	4-20 mA, 0-10 V	0-10 V
	Curve	Curve submenu		
	Unit	Flow rate unit	m ³ /h, l/min	l/min
	Volt 1	Voltage minimum flow rate (only if 0-10 V has been selected)	0.0 ... 10.0 V	1.0 V
U/I	Current 1	Current minimum flow rate (only if 4-20 mA has been selected)	0 ... 20 mA	4 mA
	Fl.r.1	Minimum flow rate	0.0 ... 500.0 l/min 0.0 ... 30.0 m ³ /h	1.0 l/min 1.0 m ³ /h
	Volt 2	Voltage maximum flow rate (only if 0-10 V has been selected)	0.0 ... 10.0 V	10.0 V
	Current 2	Current maximum flow rate (only if 4-20 mA has been selected)	0 ... 20 mA	20 mA
	Fl.r.2	Maximum flow rate	0.0 ... 500.0 l/min 0.0 ... 30.0 m ³ /h	10.0 l/min 10.0 m ³ /h
FlowRotor	FlowRotor	Type	DN20, DN25, DN32	DN20
VFS	VFS	Type	2-40, 1-12	2-40
V40	V40	Impulse rate	0.1 ... 100.0 l/Imp	1.0 l/Imp

The characteristic curve of the voltage and current signal as a function of the flow rate is defined by 2 set points. At a flow rate of **Fl.r.1** the voltage signal is **Volt 1** and the current signal **Current 1** respectively. At a flow rate of **Fl.r.2** the voltage signal is **Volt 2** and the current signal **Current 2** respectively. The device automatically calculates the characteristic curve resulting from these values.



Note

The flow rate sensor has to be installed in the return.

Voltage signal in V/Current signal in mA

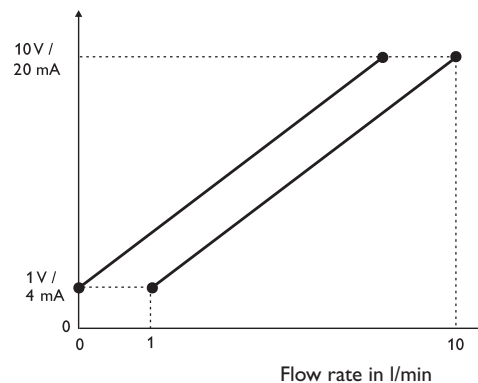

5 Commissioning

When the system is ready for operation, establish power supply of the device.

The device runs an initialisation phase in which the Lightwheel® glows red.

When the device is commissioned or when it is reset, it will run a commissioning menu after the initialisation phase. The commissioning menu leads the user through the most important adjustment channels.

Commissioning menu

The commissioning menu consists of the channels described in the following. In order to make an adjustment, adjust the desired value with the Lightwheel® and confirm with the right button (✓). The next channel will appear in the display.

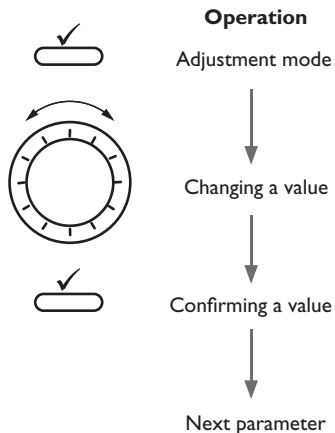

1. Language:

→ Adjust the desired menu language.

Sprache ▼
 Deutsch
 ▶ English
 Français

2. Daylight savings time adjustment:

→ Activate or deactivate the automatic daylight savings time adjustment.

Auto DST ▼
 Yes
 No

3. Time:

→ Adjust the clock time. First of all adjust the hours, then the minutes.

Time
 12:15
 ▲

4. Date:

→ Adjust the date. First of all adjust the year, then the month and then the day.

Date
 ?? ?? 2019
 ▲

5. Cascade:

→ If the device is to be used in a cascade, select **Yes**.

Cascade ▼
 Yes
 No

6. Bus mode (if 5. = Yes):

→ Define whether the device is used as a master with a controller, as a master or as a slave.

Bus mode ▼
 M,+ C.
 Master
 Slave 1

7. Flow rate sensor:

→ Adjust the desired flow rate sensor.

Depending on the flow rate sensor selected further adjustment channels appears, see page 11.

8. Medium:

→ Adjust the desired heat transfer fluid.

If **Tyfoacor LS**, **Ethyl** or **Propyl.** has been selected, another channel for adjusting the antifreeze concentration appears.

→ Adjust the desired **concentration** of the heat transfer medium.

9. Metering:

→ Adjust the desired energy metering.

10. Alternative unit:

→ Activate or deactivate the alternative unit.

If the alternative unit is activated, further channels appear:

→ Adjust the desired **Unit**.

→ Adjust the desired **Factor**.

11. Second HQM?

→ Activate a second heat quantity measurement, if required.



Note

If a second calorimeter is activated, the channels described above will be displayed for the second heat quantity measurement.

The flowchart illustrates the sequence of menu screens during the commissioning process. It starts with the 'Flow rate' screen, followed by 'Fluid type', 'Metering', 'Alternative unit', and finally 'Second HQM?'. Each screen has a dropdown arrow on the right side, and the selected option is indicated by a radio button or a checkmark.

- Flow rate:** Options are FlowRotor, VFS, and V40 (selected).
- Fluid type:** Options are Ethyl., Propyl., and Water (selected).
- Metering:** Options are Combined, Cold, and Heat (selected).
- Alternative unit:** Options are Yes and No (selected).
- Second HQM?:** Options are Activated and Deactivated (selected).

12. Completing the commissioning menu:

After the adjustments have been made, a security enquiry appears. If the security enquiry is confirmed, the adjustments will be saved.

→ In order to confirm the security enquiry, press the right button (✓).

→ In order to get back to the adjustment channels of the commissioning menu, press the left button (←).

After the security enquiry has been confirmed, the device is ready for operation.



Note

The adjustments carried out during commissioning can be changed anytime in the corresponding adjustment channel. Additional functions and options can also be activated and adjusted.

The 'Save?' screen is a simple dialog box with a title bar 'Save?' and a dropdown arrow on the right. It contains two radio button options: 'Yes' (selected) and 'No'.

6 Main menu

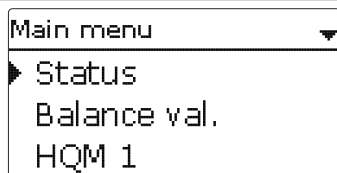

In this menu, different menu areas can be selected.

The following menus are available:

- Status
- Balance values
- HQM 1
- HQM 2
- Basic settings
- SD card
- User code

➔ Select the menu area by turning the Lightwheel®.

➔ In order to access the desired menu area, press the right button (✓).

During normal operation of the device, the display indicates the main menu.

If no button is pressed for 2 min, the display illumination switches off. After another 2 min, the device changes to the status display.

➔ In order to get from the status menu into the main menu, press the left button (↶)!

7 Status

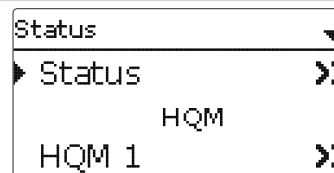

The status menu is divided into the menu areas **Status**, **HQM** and **Service**.

7.1 Status

In the **Status/Status** menu, all current measured values are indicated in a clear graphic. Each HQM has its own display. In order to change between HQM 1 and HQM 2, turn the Lightwheel®.

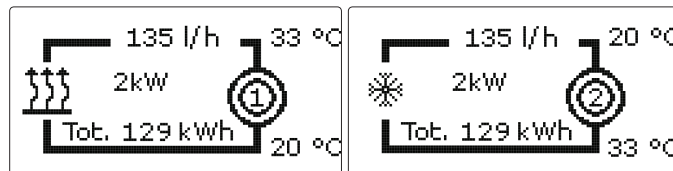

The information given in the graphic can also be indicated as a text. For this purpose, select the desired HQM and press the right button (✓). In order to get back to the graphic, press the left button (↶).

Symbol	Description
	HQM 1
	HQM 2
	Heat generator (if heat quantity is metered)
	Cold generator (if cold quantity is metered)

7.2 HQM

In the **Status/HQM** menu, the submenus **HQM 1** and **HQM 2** can be found in which all current measured values of the flow and return sensors, flow rate and power as well as heat quantity of the corresponding calorimeter are indicated.

7.3 Service

In the **Status/Service** menu, the **Messages** submenu can be found in which error and warning messages are indicated.

During normal operation, the message **Everything OK** is indicated.

In case of an error message, the display indicates the error type.

After the error has been removed, the error message will disappear.

Display	Description
HQM 1 !Fl. def.	HQM 1 Flow sensor defective (short-circuit or line break)
HQM 1 !Ret. def.	HQM 1 Return sensor defective (short-circuit or line break)
HQM 2 !Fl. def.	HQM 2 Flow sensor defective (short-circuit or line break)
HQM 2 !Ret. def.	HQM 2 Return sensor defective (short-circuit or line break)
!Date/Time	Clock module failed
!Data storage def.	Data storage defective
Card full	SD card full
Metering stopped	Parameterisation mode active

8 Balance values



Balance val.

▶ HQM 1
back

In the **Balance values** menu, all balance values of the corresponding calorimeter are indicated. If, for example, **HQM 1** is selected, a submenu indicating all current values of the first calorimeter opens.

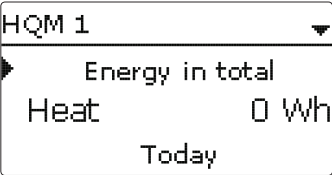

HQM 1

▶ Energy in total
Heat 0 Wh
Today

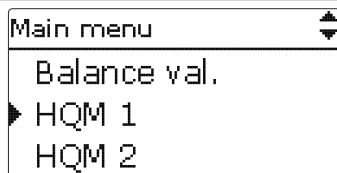

In the **HQM 1** and **HQM 2** menus, up to 2 internal heat quantity measurements can be activated and adjusted.

HQM 1 and HQM 2 respectively

Adjustment channel	Description	Adjustment range/selection	Factory setting
Sen. flow rate	Flow rate sensor selection	US Echo II, SIKA, U/I, FlowRotor, VFS, V40	-
US Echo II	Impuls rate	0.1 ... 100.0 l/Imp	1.0 l/Imp
SIKA	Type	VY1030M, VY1030K, VTY20	VTY20
U/I	Voltage or current signal	4-20 mA, 0-10 V	0-10 V
Curve	Curve submenu		
Unit	Flow rate unit	m ³ /h, l/min	l/min
Volt 1	Voltage minimum flow rate (only if 0-10 V has been selected)	0.0 ... 10.0 V	1.0 V
Current 1	Current minimum flow rate (only if 4-20 mA has been selected)	0 ... 20 mA	4 mA
Fl.r.1	Minimum flow rate	0.0 ... 500.0 l/min 0.0 ... 30.0 m ³ /h	1.0 l/min 1.0 m ³ /h
Volt 2	Voltage maximum flow rate (only if 0-10 V has been selected)	0.0 ... 10.0 V	10.0 V
Current 2	Current maximum flow rate (only if 4-20 mA has been selected)	0 ... 20 mA	20 mA
Fl.r.2	Maximum flow rate	0.0 ... 500.0 l/min 0.0 ... 30.0 m ³ /h	10.0 l/min 10.0 m ³ /h
FlowRotor	Type	DN20, DN25, DN32	DN20
VFS	Type	2-40, 1-12	2-40
V40	Impuls rate	0.1 ... 100.0 l/Imp	1.0 l/Imp
Fluid type	Heat transfer fluid	Tyfocon LS, Ethyl., Propyl., Water	Water
Concentr.	Glycol concentration in the heat transfer fluid (only if fluid type = propylene glycol or ethylene glycol)	20 ... 70%	40%

Adjustment channel	Description	Adjustment range/selection	Factory setting
Metering	Selection of quantity to be metered	Combined, Heat, Cold	Heat
Alternative unit	Alternative unit option	Yes, No	No
Unit	Alternative display unit	Coal, Gas, Oil, CO ₂ , €	CO ₂
Factor	Conversion factor	0.0000001 ... 100.0000000	0.5000000
S0 output	Switch input selection	-	-
Duration	Impulse duration	30 ... 120 ms	100 ms
Break	Impulse break	30 ... 120 ms	30 ms
Imp/kWh	Impulse rate	1 ... 1000	100
Reset	back to factory setting	Yes, No	No
Funct.	Activation / Deactivation	Activated, Deactivated	Activated

S1 is the flow sensor, S2 is the return sensor. If **VFS** has been selected as the flow rate sensor, the return temperature is measured automatically via the VFS sensor. In this case, the return sensor can be changed with the **Sen. return** parameter.

Depending on the flow rate sensor selected further adjustment channels appear, see page 11.

In the adjustment channel **Fluid type** the heat transfer fluid must be selected. If either propylene glycol or ethylene glycol is selected, the adjustment channel **Concentration** is indicated in which the antifreeze ratio of the heat transfer fluid can be adjusted.

For temperatures below 0 °C a heat transfer fluid with antifreeze is to be used.

The **Metering** channel is used for selecting whether heat quantity, cold quantity or both are to be metered.

When the **Alternative unit** option is activated, the device will convert the energy quantities into the quantity of fossil fuels (coal, oil or gas) saved, or the CO₂ emission saved respectively. The alternative **Unit** can be selected. A **factor** must be adjusted for the calculation. The conversion factor depends on the arrangement in use and has to be determined individually.

In the **S0 output** menu, a digital impulse output can be adjusted for each calorimeter, in order to issue the energy metered in form of pulses. The impulse duration, break and rate can be adjusted.

In order to reset the settings of a calorimeter, select **Reset** and confirm the security enquiry with **Yes**.

With the menu item **Function**, a calorimeter already adjusted can be temporarily deactivated or re-activated respectively. In this case, all adjustments will remain stored. If a calorimeter is deactivated, energy metering does not take place by this one. Sensor faults are ignored for the deactivated HQM.

10 Single and cascade operation

The WMZ Plus can be used as a single device or in a cascade. Up to 8 WMZ Plus can meter 16 heat quantities in total. If several WMZ Plus are used, the master has to be adjusted first.

The following possibilities are available:

10.1 Single operation

In single operation, one WMZ Plus can be connected to VBus[®] accessories.



Adjustment WMZ Plus:

Cascade = No; Bus mode = Single

10.2 Cascade without controller

In cascade operation, several WMZ Plus can be connected to each other via the VBus[®].

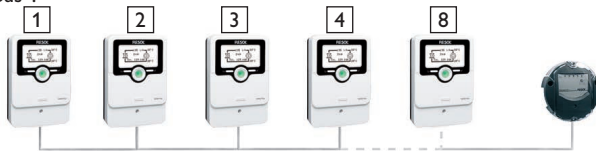

Adjustment WMZ Plus 1:

Cascade = Yes; Bus mode = Master

Adjustment WMZ Plus 2 to 8:

Cascade = Yes; Bus mode = Slave 1 ... 7

10.3 Cascade with controller

In cascade mode, one or several WMZ Plus can be connected to one controller via the VBus[®].

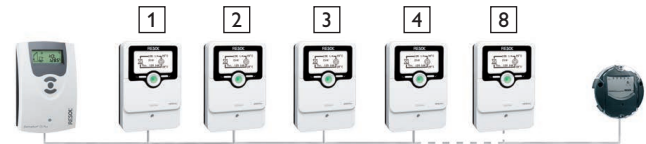

Adjustment WMZ Plus 1:

Cascade = Yes; Bus mode = M.+C.

Adjustment WMZ Plus 2 to 8:

Cascade = Yes; Bus mode = Slave 1 ... 7

11 Basic settings

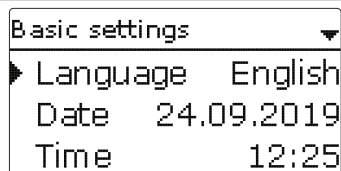

In the **Basic settings** menu, all basic parameters for the device can be adjusted. Normally, these settings have been made during commissioning. They can be subsequently changed in this menu.

Basic settings

Adjustment channel	Description	Adjustment range/selection	Factory setting
Language	Selection of the menu language	Deutsch, English, Français, Español, Italiano	Deutsch
Date	Adjustment of the date	01.01.2001 ... 31.12.2099	01.01.2012
Time	Adjustment of the current time	00:00 ... 23:59	-
Auto DST	Daylight savings time selection	Yes, No	Yes
Flow unit	Volume unit	l, m ³	l
Bus mode	Bus mode single/cascade operation	M.+C., Master, Slave 1 ... 7	-
Reset	back to factory setting	Yes, No	No

12 MicroSD card

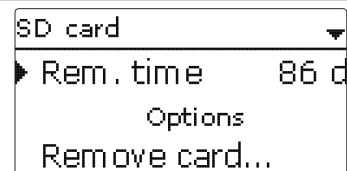

SD card

Adjustment channel	Description	Adjustment range/selection	Factory setting
Rem. time	Remaining logging time	-	-
Remove card...	Safely remove card	-	-
Save adjustments	Save adjustments	-	-
Load adjustments	Load adjustments	-	-
Logging int.	Interval for data logging	00:01 ... 20:00 (mm:ss)	60:00
Logging type	Logging type	Cyclic, Linear	Linear

The device is equipped with a MicroSD card slot for MicroSD memory cards.

With a MicroSD card, the following functions can be carried out:

- Logging measurement and balance values. After the transfer to a computer, the values can be opened and visualised, e.g. in a spreadsheet.
- Store adjustments and parameterisations on the MicroSD card and, if necessary, retrieve them from there.
- Running firmware updates on the device.

Firmware updates

The current software can be downloaded from www.resol.de/firmware. When a MicroSD card with a firmware update is inserted, the enquiry **Update?** is indicated on the display.

➔ In order to run an update, select **Yes** and confirm with the right button (✓).

The update will run automatically. The indication **Please wait** and a progress bar appear on the display. When the update has been completed, the device will automatically reboot and run a short initialisation phase.



Note

Only remove the card when the initialisation phase has been completed and the main menu is indicated on the device display!

→ To skip the update, select **No**.

The device starts normal operation.



Note

The device will only recognise a firmware update file if it is stored in a folder named **RESOLIWMZ** on the first level of the MicroSD card.

→ Create a folder named **RESOLIWMZ** on the MicroSD card and extract the downloaded ZIP file into this folder.

Starting the logging

→ Insert the MicroSD card into the slot.

→ Adjust the desired logging type and interval.

Logging will start immediately.

Completing the logging process

→ Select the menu item **Remove card...**

→ After **Remove card** is displayed, remove the card from the slot.

When **Linear** is adjusted in the logging type adjustment channel, data logging will stop if the capacity limit is reached. The message **Card full** will be displayed.

If **Cyclic** is adjusted, the oldest data logged onto the SD card will be overwritten as soon as the capacity limit is reached.



Note

Because of the increasing size of the data packets, the remaining logging time does not decrease linearly. The data packet size can increase, e.g. with the increasing operating hours value.

Saving adjustments

→ To store the adjustments on the MicroSD card, select the menu item **Save adjustments**.

While the adjustments are being stored, first **Please wait**, then **Done!** will be indicated on the display. The adjustments are stored as a .SET file on the MicroSD card.

Loading adjustments

→ To load adjustments from a MicroSD card, select the menu item **Load adjustments**.

The File selection window will appear.

→ Select the desired .SET file.

While the adjustments are being loaded, first **Please wait**, then **Done!** will be indicated on the display.



Note

To safely remove the MicroSD card, always select the menu item **Remove card...** before removing the card.

User code:

0000

In the **User code** menu, a user code can be entered. Each number of the 4-digit code must be individually adjusted and confirmed. After the last digit has been confirmed, the menu automatically jumps to the superior menu level.

To access the menu areas of the installer level, the installer user code must be entered:

Installer: 0262

If the installer user code has been entered, the device changes to the parameterisation mode, see page 9.



Note

For safety reasons, the user code should generally be set to the customer code before the device is handed to the customer!

Customer: 0000

If a parameter of the installer level is to be changed without previously having entered the user code, the user code enquiry appears. Only if the installer user code has been entered, can the parameter be changed.

14 Troubleshooting

If a malfunction occurs, a message will appear on the display of the device.

WARNING! Electric shock!



Upon opening the housing, live parts are exposed!

→ **Always disconnect the device from power supply before opening the housing!**

The device is protected by a fuse. The fuse holder (which also holds the spare fuse) becomes accessible when the cover is removed. To replace the fuse, pull the fuse holder from the base.

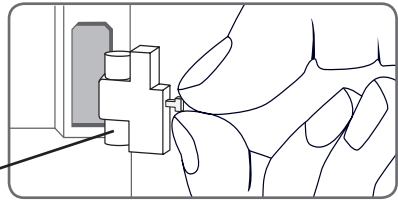

Fuse

The Lightwheel® flashes red.

Sensor fault. An error code instead of a temperature is shown on the sensor display channel.

Short circuit or line break. Disconnected temperature sensors can be checked with an ohmmeter. Please check if the resistance values correspond with the table.

°C	Ω Pt1000	°C	Ω Pt1000
-10	961	55	1213
-5	980	60	1232
0	1000	65	1252
5	1019	70	1271
10	1039	75	1290
15	1058	80	1309
20	1078	85	1328
25	1097	90	1347
30	1117	95	1366
35	1136	100	1385
40	1155	105	1404
45	1175	110	1423
50	1194	115	1442

The display is permanently off.

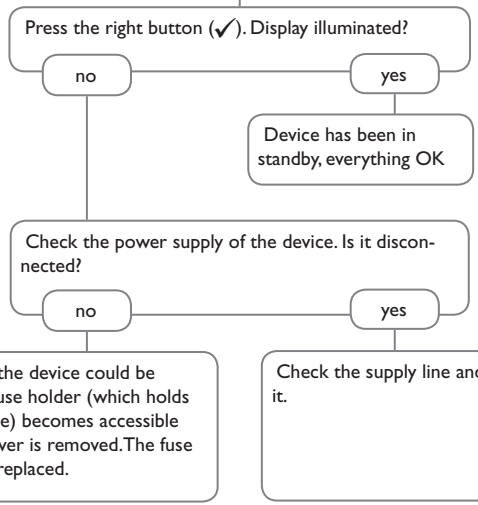



Sensors



Overvoltage protection device



Grundfos Direct Sensor™ VFS



V40 Flowmeter



VBus® / USB & VBus® / LAN interface adapters



AM1 Alarm module



KM2 Communication module



DL2 Datalogger



DL3 Datalogger





DL3 Datalogger

For visualisation via VBus.net, incl. SD card, mains adapter, network and VBus® cable.



DL2 Datalogger

For visualisation via VBus.net, incl. SD card and network cable, mains adapter and VBus® cable pre-connected.



KM2 Communication module

For visualisation via VBus.net, incl. SD card and network cable, mains adapter and VBus® cable pre-connected.



VFS Grundfos Direct Sensors™

Analogue sensors in different versions



V40 Flowmeter

The V40 is a measuring instrument for detecting the flow of water or water/glycol mixtures.



AM1 Alarm module

Alarm module for signalling system failures



SP10 Overvoltage protection device

Overvoltage protection device, suitable for mounting outdoors.



VBus®/USB & VBus®/LAN interface adapters

With the RESOLVBus®/USB interface adapter, the controller can be connected to the USB port of a PC via the VBus®.

The VBus®/LAN interface adapter is designed for the direct connection of the controller to a PC or router. It enables easy access to the controller via the local network of the owner.



VBus®-Repeater

The VBus®-Repeater amplifies the VBus® signal of a controller and supplies a current of 200 mA in total to modules connected.



Sensors

The product range includes high-precision platinum temperature sensors, flatscrew sensors, outdoor temperature sensors, indoor temperature sensors, cylindrical clip-on sensors, also as complete sensors with immersion sleeve.

VBus.net

The Internet portal for easy and secure access to your system data. VBus.net is all about the data of your controller. Live data of your system, customised filter settings and much more await you.

A		M	
Alternative unit.....	16	Messages	15
B		MicroSD card	19
Balance values	15	Mounting	5
Basic settings.....	18	P	
Buttons and adjustment dial	8	Parameterisation mode	9
C		R	
Calorimeter.....	16	Reset.....	16
Cascade	17	S	
Commissioning menu.....	12	S0 output.....	16
Control lamp.....	8	Status	14
D		Storing adjustments	19
Data communication / Bus.....	7	T	
Data logging.....	19	Technical data.....	4
E		U	
Electrical connection	6	User code	19
Error message.....	15	V	
F		VBus®	7
Firmware updates	18		
Flow rate sensors.....	11		
Fuse, replacing of.....	20		
H			
HQM.....	16		
L			
Language.....	18		
Lightwheel®	8		
Load adjustments	19		
Logging interval.....	18		

Distributed by:

RESOL – Elektronische Regelungen GmbH

Heiskampstraße 10
45527 Hattingen / Germany

Tel.: +49 (0) 23 24 / 96 48 - 0

Fax: +49 (0) 23 24 / 96 48 - 755

www.resol.com

info@resol.com

Important note

The texts and drawings in this manual are correct to the best of our knowledge. As faults can never be excluded, please note:

Your own calculations and plans, under consideration of the current standards and directions should only be basis for your projects. We do not offer a guarantee for the completeness of the drawings and texts of this manual - they only represent some examples. They can only be used at your own risk. No liability is assumed for incorrect, incomplete or false information and / or the resulting damages.

Note

The design and the specifications can be changed without notice.
The illustrations may differ from the original product.

Imprint

This mounting- and operation manual including all parts is copyrighted. Another use outside the copyright requires the approval of **RESOL – Elektronische Regelungen GmbH**. This especially applies for copies, translations, micro films and the storage into electronic systems.

© **RESOL – Elektronische Regelungen GmbH**